

SNARE MIC

QUICK START GUIDE

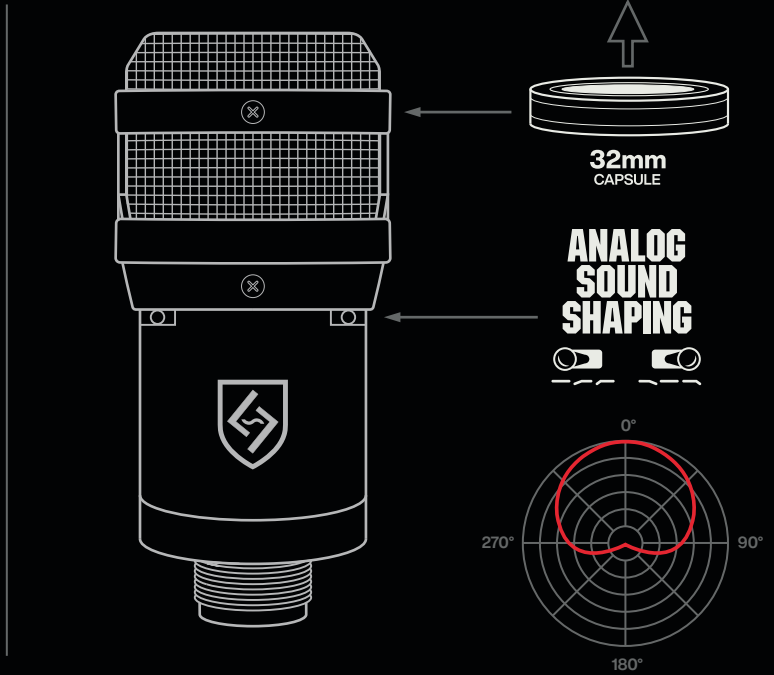

SOUND SHAPING

FLAT/FLAT = HIGH IMPACT

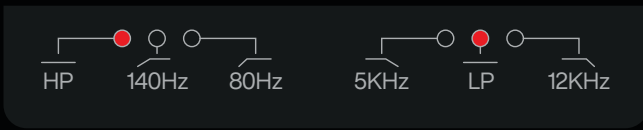

80Hz/12kHz = EQ'D DYNAMIC MIC

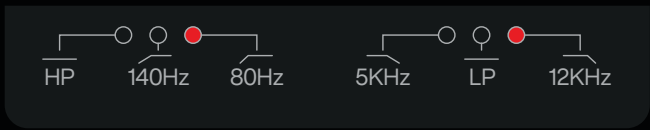

140Hz/5kHz = BLEED DECIMATOR

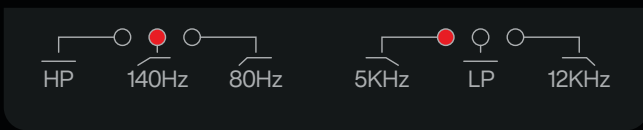

140Hz/FLAT = BOTTOM SNARE

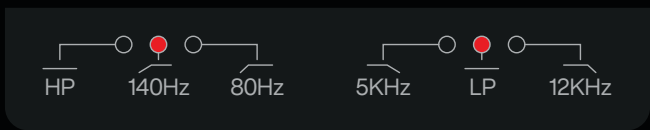

MIC PLACEMENT

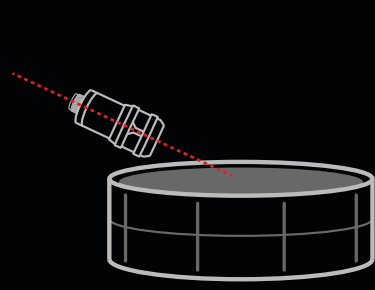

20-30 Degrees
Increased crack & top head snap.

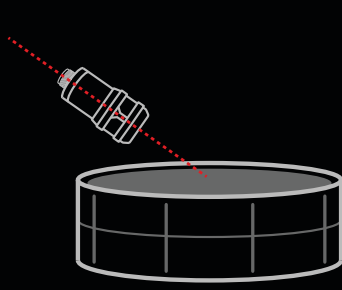

30-40 Degrees
Bottom-end punch and increased midrange.

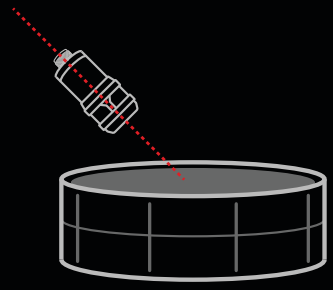

40-50+ Degrees
Accentuated bottom-end, body, and woof.

+48V SNARE MIC REQUIRES 48V OF PHANTOM POWER TO WORK